

Overview of Emerging Broadband Wireless Technologies for Transportation

By:

Ashwin Amanna (ashwin@vtti.vt.edu)
Senior Research Associate
Virginia Tech Transportation Institute

November 11, 2008



Executive Summary

Departments of Transportation depend considerably on communications between Intelligent Transportation Systems (ITS) field devices and Transportation Operations Centers (TOC). The future of transportation operations is expected to grow beyond just fixed devices to incorporate vehicle-to-vehicle and vehicle-to-roadside wireless communications. The interaction between vehicles, roadway management and critical roadway infrastructure will play a major role in the new national paradigm of cyber-physical systems (the integration of computation with physical processes) . Wireless communications will be the fabric that ties together these major subsystems.

Fiber optics and traditional telephony wire line solutions provide reliable communications links; however, they can be expensive, bandwidth-limited, or unavailable in some areas. Broadband wireless communications is proving to be a viable alternative to wired mediums for providing connectivity to field devices. A previous VTTI report assessed in detail the current state of available wireless technologies and presented recommendations for usage in Department of Transportation (DOT) applications. While today's technologies are helping to meet the operational needs of DOTs, a new era of wireless communications technologies is poised to emerge over the next several years.

The report discusses important long-term issues such as spectrum usage, future proofing investments as technology cycles, and advanced technologies for creating wireless links that are robust to interference and jamming. Military and Public Safety agencies, with similar communications needs as DOTs, are beginning to adopt these advanced techniques. Emerging technologies such as Mobile WiMAX, Software-Defined Radio, Cognitive Radio, and Femtocell short range cellular are discussed that have potential to dramatically affect DOT operations as well as vehicle-to-vehicle and vehicle-to-roadside communications.

Wireless communication technologies cycle at a rapid pace with major improvements developing every 3-5 years. Broadband wireless is currently entering a new cycle which will significantly change the wireless landscape as we know it today. DOTs are urged to aggressively monitor and apply emerging technologies to operations and security as well as to support interoperability among other state and federal agencies.

Table of Contents

1.0 Major Long-Term Issues to Consider	4
1.1 Spectrum Issues	4
1.2 Future Proofing Investments.....	5
1.3 Interoperability.....	6
1.4 Hidden Costs.....	6
2.0 Emerging Technologies and Future Solutions.....	8
2.1 Software-Defined (Data) Radio-SDR.....	9
2.2 Cognitive Radio	10
2.2.1 Brokering of DOT-owned spectrum using DSA and cognitive technology	13
2.4 IEEE 802.20.....	13
2.5 IEEE 802.22.....	13
2.6 Ultra-wideband (UWB)	14
2.7 IEEE 802.11p.....	14
2.8 Femtocell Short Range Cellular.....	15
2.9 Long-Term Evolution (LTE)	17
2.10 WiMAX	17
3.0 Recommended Technologies to Research	18
3.1 Mobile WiMAX.....	18
3.2 Software Defined Radio/Cognitive radio.....	18
3.3 802.22 and Whitespace technologies.....	19
4.0 Conclusions.....	19

1.0 Major Long-Term Issues to Consider

It is generally accepted that broadband wireless technologies are a valid tool for meeting some of the communications needs of DOT Operations Programs. In many situations, conventional communications are not viable options due to terrain or limited connectivity. In other situations, expensive wire line installations do not make sense such as for temporary cameras. Finally, the speed in which wireless systems can be deployed in comparison to fiber optics can be more desirable.

As the use of broadband wireless by DOTs, other state agencies, and the public at large grows, there are several major issues that need to be considered. While these issues are not 'show stoppers' that will delay any individual installation, they are important in the long-term and can cause significant problems if not considered today. These issues include spectrum scarcity/spectrum management, future proofing technology investment, interoperability between DOT users and public agencies, and optimizing deployment/long-term operational costs.

1.1 Spectrum Issues

Many of the wireless technologies feasible for use by DOT utilize unlicensed spectrum. These spectrum ranges include the 900MHz, 2.4GHz, 5.8GHz, and 4.9GHz bands. The 4.9GHz band is limited to public safety uses, which reduces the number of potential interferers, but there is still a chance for interference from other devices in the spectrum range. Relative to the entire available spectrum, the unlicensed pieces are fairly small. One of the issues facing not only DOTs, but all users of unlicensed spectrum, is the relative shrinking of available spectrum. As more and more users cram into limited spectrum ranges, the potential for interference from other devices increases. This issue is especially prevalent in more urban areas where there are higher relative numbers of users. Vehicle Infrastructure Integration (VII) deployment is still in flux regarding how and in what density it is going to be deployed. However, there is little doubt that it will require a significant use of spectrum and, as vehicle density grows, there are limitations as to how much density can be supported within the available spectrum.

Another spectrum issue that DOTs need to stay abreast of relates to the efforts to allocate 700MHz for public safety. Recently, almost \$20 billion dollars was raised when the FCC auctioned off blocks of the 700MHz spectrum. The reason 700MHz is considered 'beachfront' property is due to the incredible propagation characteristics compared to bands such as 2.4GHz, 4.9GHz, and 5.8GHz. The cell sizes for a 700MHz system will be much larger, and therefore much more economical, to build out.

During the auction, the FCC set aside a block known as the “D” block that specified allocations strictly for public safety use. There was a stipulation in the bidding for this block that the winner had to deploy a system that could be utilized by public safety. It is speculated that this requirement scared off potential bidders and the D block did not sell during the auction. This 700MHz allocation for public safety would have been of significant benefit to DOTs for safety and operations.

The propagation characteristics of 700MHz make it ideal for rural areas and for the hilly and curving terrain of highways. It is imperative that DOTs lobby state and Federal government to leverage the FCC to move forward with a permanent public safety allocation in the 700MHz band. Currently, the FCC has gone back to the drawing board for how to proceed with this unsold block. An official FCC notice of proposed rulemaking (NPRM) was published in June 2008 and the official comment period ends June 20, 2008. The general consensus is that the FCC will make a final rulemaking in late July or August, 2008 [1]. A nationwide public safety network would require a large dedicated funding allocation from Congress or a significant public/private partnership. Other issues still on the table include licensing on a regional basis and whether the block should be limited to public safety use only.

There will be some 700MHz spectrum set aside for State use; however, its control will most likely fall under statewide Information Technologies Agency whereas a specific public safety allocation would typically not require interaction between DOT and state Information agencies.

Recently, there has been significant interest in the ‘white spaces’ within the wireless spectrum. White space denotes periods of time where a spectrum is not being used by the original owner. Data traffic that is bursty, meaning that it is not sent continuously, creates whitespaces. Companies such as Google and Microsoft are lobbying the FCC heavily to develop devices that can search out whitespaces without adversely affecting the incumbent spectrum owner.

In order to utilize these whitespaces, devices must have the capability to sense the wireless spectrum, identify whitespaces, and vacate whitespaces in a timely manner if an incumbent is sensed. This technology is currently in development and may be available in less than 10 years. These devices would potentially operate in TV bands which have excellent propagation characteristics. DOTs should monitor activity in the whitespace devices area for potential application to DOT security and operations.

1.2 Future Proofing Investments

Typical ITS devices such as dynamic message signs (DMS) and CCTV cameras have long-term life spans of over 15 years. DOT procurements tend to follow this long-term life span. Wireless devices, similar to personal computers, tend to follow a much faster timeline. Typically, computer technology follows a 3-5 year

cycle. In this cycle, new technologies become available that performs better at the same or lower price points. These advancements are suggested by Moore's Law which reflects the growth in the number of transistors that can be inexpensively placed on an integrated circuit doubles every two years.

The timelines in which procurements take place can make DOTs susceptible to deploying obsolete technology. The design phase often takes place more than a year out of deployment. By the time the project is bid, awarded, and construction is completed, the deployed technology may be 3 years old.

In addition to rapid advancements in technology, the spectrum landscape can often change. New sources of interference caused by random noise or other users in the spectrum can cause performance degradations. If this occurs, there is potential that a device in a new spectrum will be required. A similar situation can be experienced if there is a change in scope for large scale deployments such as with VII. In the next section, new advancements will be discussed that address the capability for future proofing DOT investment in wireless technology.

1.3 Interoperability

Interoperability between DOT deployments as well as between DOT and other state agencies is of paramount importance. Currently, wireless deployments are performed in an isolated manner with each system being designed and deployed independently between the different DOT regions. In addition, there are a myriad of deployments ongoing across the varied public safety agencies including police, fire, homeland security, and county agencies. In times of need such as natural disasters, evacuations, or security threats, some method for achieving interoperability between the varied wireless communications networks is desired.

1.4 Hidden Costs

When deploying wireless networks there are 'hidden' costs that are not typically thought of by the deploying agency. Newer technologies as discussed in the next section could mitigate some of these costs. By making wireless technologies easier to deploy and manage, significant cost savings could be realized in the areas of deployment and long-term management.

Designing and deploying a wireless network currently requires significant specialized personnel in the areas of wireless radio frequency (RF) design and wireless networking. Preliminary site surveys, along with antenna setup, IP networking, channel frequency allocation, and frequency reuse all fall underneath the purview of the systems integrator. These technical jobs all add to the significant costs for deploying a wireless system above and beyond the wireless equipment, which is actually relatively low cost when compared to the personnel and construction resources. Any advancement that can limit the requirement for specialized personnel would bring down the initial deployment costs.

Long-term operating costs can potentially add up for the DOT owner of wireless networks. As shown in Figure 1, interference caused by random noise or other users can affect the quality of a wireless signal which in turn could affect the end application such as a camera signal.

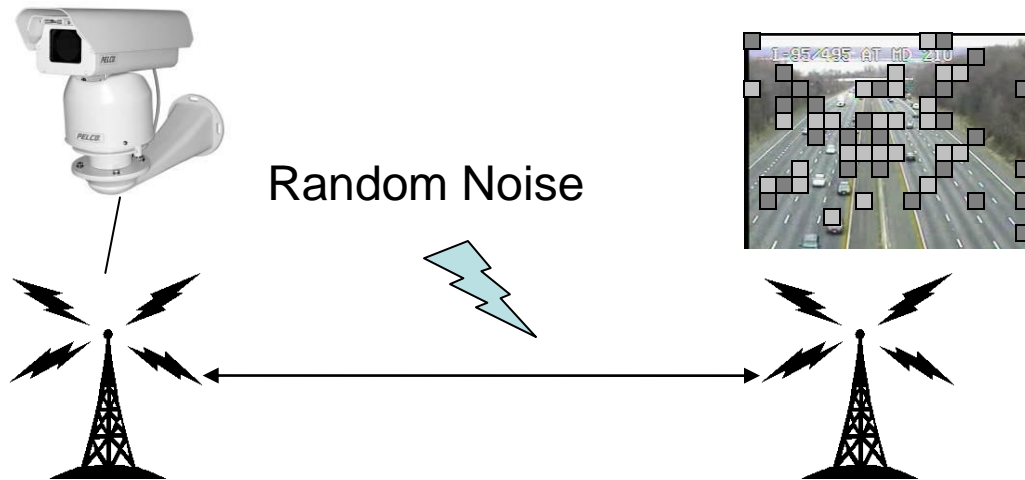

Figure 1 Effect of Noise on a Camera Signal

Maintenance of these wireless links will most likely fall underneath DOT ITS maintenance contracts. Anomalies in link quality that affect camera or other data signals will most likely generate a trouble call. For a few wireless links here and there this is not significant; however, as wireless deployments grow and large scale usage grows these issues can add up into significant operating costs. Technologies presented in the next section can address decreasing long-term operating costs created by changing wireless landscapes.

2.0 Emerging Technologies and Future Solutions

Wireless usage has seen explosive growth in an extremely short time frame. Less than 10 years ago, the thought of ubiquitous wireless connectivity was a mere dream. Today the concept has become almost a certainty. The growing demand for wireless has spurred continual development into better technologies. DOTs can leverage off this development and take advantage of the investment made by sister agencies such as Public Safety and the Military. Similarly to DOTs, these agencies have need of reliable, robust and interoperable communications. This section discusses emerging wireless concepts and technologies that will have significant relevance to DOTs in the near future. Table 1 summarizes the emerging technologies.

Table 1 Summary of Emerging Technologies

Technology	Concept	Advantages	Timeframe
Software Defined Radio (SDR)	Reconfigurable radios	<ul style="list-style-type: none"> • Future Proof • Promotes Interoperability 	1-5 years
Cognitive Radio	Radios that are aware of the environment and can learn	<ul style="list-style-type: none"> • Adaptable to interference • Enhanced Operation • Lower Deployment Costs • Lower maintenance Costs 	5-10 years
802.20	Packet Switched IP Network	<ul style="list-style-type: none"> • Specifically designed for Internet Protocol 	n/a
802.22	Cognitive based using the 700MHz band	<ul style="list-style-type: none"> • Large coverage area • High bandwidth • Developed with cognitive technology in mind 	5-10 years
Ultra Wideband (UWB)	Short range, low power in ultra high bandwidth	<ul style="list-style-type: none"> • Low interference with other networks • Very high bandwidths • Pinpoint precision location possible 	5-10 years
802.11p Dedicated Short Range Communications (DSRC)	Standard specifically for vehicle to vehicle and vehicle to roadside	<ul style="list-style-type: none"> • Low latency • Priority for safety critical systems 	2-5 years
Femtocell	Short range cellular base station	<ul style="list-style-type: none"> • Can provide an alternative to DSRC • Low cost equipment 	2-5 years

		<ul style="list-style-type: none"> • Supports a Business plan for VII that DSRC does not fulfill • Flat network 	
LTE	Next generation digital cellular	<ul style="list-style-type: none"> • Designed for Digital voice and data • Less need for LOS 	3-5 years
WiMAX	Base station based digital data network by Sprint/Clearwire	<ul style="list-style-type: none"> • Designed for Digital Data • Less need for LOS 	1-5 years

2.1 Software-Defined (Data) Radio-SDR

Software-defined radios (SDR) are an emerging technology that can address issues of interoperability and future proofing DOT investments. The concept behind this is to realize some components of a radio in software and hardware as opposed to strictly in hardware. Components (such as filters, amplifiers, modulators/demodulators and other similar components) which had typically been implemented in hardware are now being implemented in software. These software-based components allow some level of re-configurability to the radio that enables some operational specifications of the radio to be changed without the need to change hardware. An analogy of this paradigm is personal computers and software used on computers. Software enables multiple applications to be run on a single hardware platform such as a personal computer. For example, without realization in software, one would need an individual computer to operate word processing, spreadsheet, and presentation programs.

SDR has been under development by the military and public safety groups for many years, with the primary emphasis placed on voice communications. The main driver has been to support interoperability between the myriad of users in military and public safety.

SDR has significant momentum behind it and, as improvements are made in technology at a rapid pace, costs will come down. SDR is widely considered to be the way the world is heading in terms of wireless communications. These types of systems enable interoperability by providing the ability for a single radio to act and operate like many different radios. Multiple agencies can operate using a single handset that can emulate any one of the types of radios in use.

Another driving force behind SDR is the potential to ‘future-proof’ the investment made in the wireless technology as fiber optics has in the wired technology. One of the issues faced by the DOT and other public agencies is that technology often outpaces the speed at which public procurements are made. Oftentimes,

technologies are obsolete or have been improved upon by the time a product is specified, procured, and deployed. Building upon an SDR platform may allow the end user to mitigate automatic obsolescence in the wireless communications device.

Currently, software based data radios are under development. These types of systems are ideally suited to a transportation application. An SDR-based wireless node could operate as a DSRRC, 802.11 spread spectrum radio or other mode. The Federal Rail Administration has sponsored SDR-based research for the past several years. Currently BSNF railroad is deploying SDR-based systems on several of their lines (Figure 2). The railway-based SDR performs voice operations in several VHF bands and also enables 2.4 GHz WI-Fi data operations.

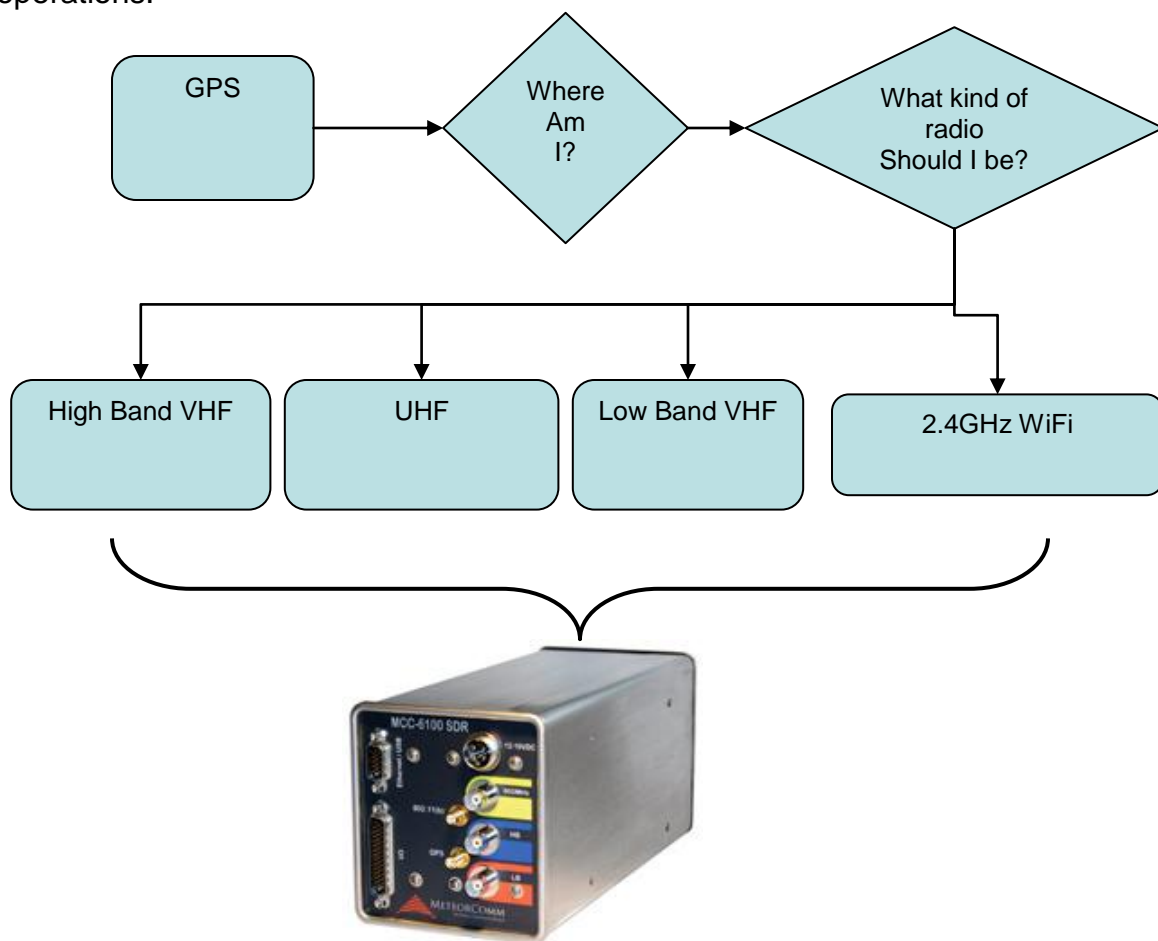

Figure 2 Software-Defined Radio in use by Railroad Industry

2.2 Cognitive Radio

The reconfigurable nature of an SDR is enabling a whole new field of wireless communications called Cognitive Radio. This new way of thinking hopes to add intelligence to how a wireless device operates. The foundations of making a

radio 'smart' are built upon a concept known as the Observe-Orient-Decide-Act (OODA) Loop (Figure 3) which breaks down the basic components of how anything from a child to potentially a wireless device can adapt to its environment.

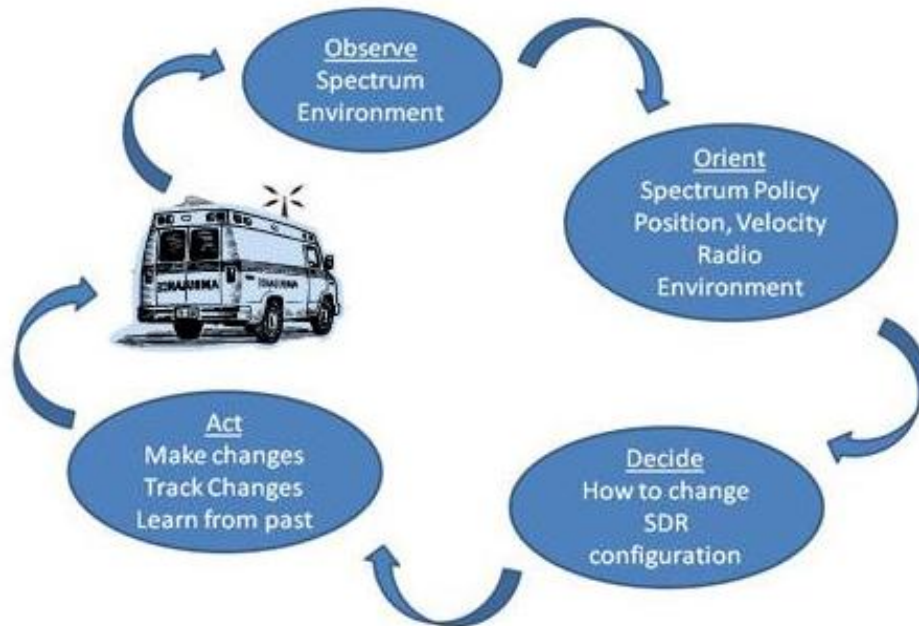

Figure 3 The OODA Loop in Action

This first step in cognition is to observe the environment in which a wireless device is operating. This observation includes metrics such as spectrum usage, available channels, identifying other emitters, classifying their origin, and taking into consideration the operating goals of the radio at a specific time. A key technology for enabling the observation of the environment is called Dynamic Spectrum Access (DSA). DSA provides the capability for the wireless device to look for open spaces in the available spectrum and to switch channels should it detect interference or jamming that would adversely affect its operation.

With this observation and knowledge of the goals, the radio utilizes machine learning algorithms to make a decision on the best course of action. Decision making is often based upon historical data regarding channel data and past successful decisions. Finally, the device utilizes the reconfigurable nature of its SDR foundation and changes key configuration parameters that allow it to react to perceived changes in the wireless environment.

An example of how cognitive radio can be used in a DOT application is a typical wireless camera system as was shown in Figure 1. Random noise or, even worse, deliberate jamming can cause interference with the wireless signal which can manifest itself as pixelization of the camera image. Wireless devices today include sophisticated coding and error correction; however, they are not always completely impervious to this type of interference.

The addition of cognitive abilities would allow the wireless link to recognize the noise or jamming and take evasive actions to mitigate around the interference (Figure 4). These actions could include changing to a new channel that has less noise on it and increasing the transmit power. Each instance of the changing configurations is recorded in a historical database as well as whether or not the changes were effective in meeting the desired goals of the system (quality video link, higher throughput, etc.). The system performance is effectively ‘trained’ through its response to changing conditions.

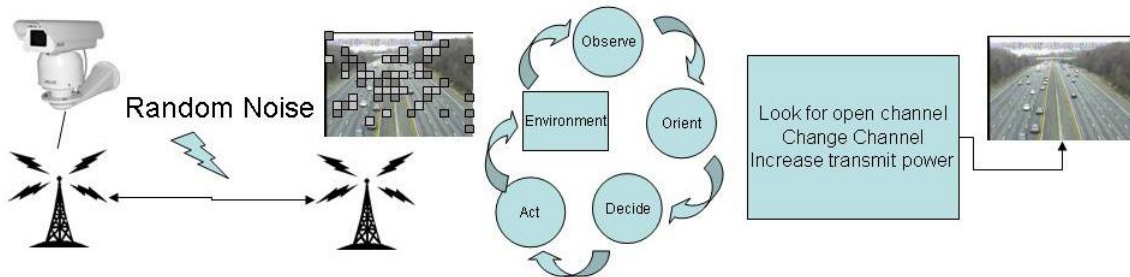

Figure 4 Wireless Link Mitigating Around Interference

In summary, cognitive radio technology can provide spectrum agility for wireless links, allowing them to mitigate around interference. This same capability enables a more efficient use of spectrum by allowing a radio to utilize white spaces within the fixed spectrum ranges similarly to increasing the amount of vehicles on a highway without increasing the number of lanes.

A significant potential benefit is the capability for self initializing and self-maintaining wireless networks. One of the major costs of any wireless deployment is the systems integrator services for design, deployment and long-term maintenance. It requires a team of highly trained wireless and network engineers to deploy each wireless link. If a radio link could sense its environment and adapt on its own, the deployment costs would be reduced to simply construction costs for mounting equipment. In addition, as the wireless landscape gets more and more crowded, wireless links are going to need more maintenance in terms of changing channels, transmit power, or other configurations to adapt to changes in the wireless environment. As DOT wireless infrastructure grows and VII is deployed throughout states, there could be several thousand wireless links. The potential maintenance costs to service these multiple wireless links will be significant. The self maintaining aspect of cognitive wireless links can reduce the long-term maintenance costs.

There are many technical challenges for cognitive radio, and the research community is actively focused in this area especially through military, public safety, and National Science Foundation (NSF) initiatives. SDR technology is fairly near term, and while cognitive radio may be farther off, these areas have significant potential for ITS and DOT operations. A proactive approach to

analyzing the feasibility of SDR and Cognitive Radio technologies for DOT operations is recommended.

2.2.1 Brokering of DOT-owned spectrum using DSA and cognitive technology

DOTs have often explored ideas for partnering with private industry in using DOT right-of-way (ROW). Cell phone towers in DOT ROW or private cameras and other sensors come to mind. There is a future potential to broker state owned wireless spectrum through the use of DSA technology. While the reality of this is most likely many years away, the idea poses merit for further exploration. If the DOT maintains control over spectrum (such as any 700MHz blocks or 4.9GHz) they could allow other users to operate within whitespaces through the use of DSA.

2.4 IEEE 802.20

IEEE 802.20 is a set of formal specifications being developed for a packet-based air interface designed for Internet Protocol-based services [2]. The next generation of mobile wireless services is going to be deployed on a packet-switched network. (A packet-switched network delivers messages between users by utilizing the address information embedded in the message without establishing a direct connection between the users. A landline telephone network, on the other hand, is a circuit-switched network where a connection needs to be maintained between users throughout the duration of call, thus resulting in a waste of bandwidth). IEEE 802.20 provides specifications that a packet-switched network needs to fulfill so as to maintain a certain level of quality of service in future wireless networks such as mobile WiMAX. Currently, the 802.20 standards development process is stalled and not moving forward.

2.5 IEEE 802.22

The IEEE 802.22 working group aims to construct a wireless regional area network (WRAN) utilizing white spaces (frequency bands that are not currently used) in the TV frequency spectrum. The use of TV spectrum will be opportunistic so as not to interfere with any ongoing transmission [3]. This standard specifies that the network should operate in a point to multipoint basis. This type of network consists of base stations (BS) and access points (AP). The medium access for all of the APs is controlled by the BS. These BSs will be capable of performing distributed spectrum sensing using cognitive radio technology. The APs collect information about available spectrum and send it to the BS which makes the decision about granting spectrum access to the APs. The physical layer of this WRAN uses orthogonal frequency division multiple access (OFDMA) modulation in the uplink and downlink, providing 19 Mbps of maximum data rate at 30 km assuming a 6MHz TV channel.

2.6 Ultra-wideband (UWB)

UWB is a personal communication technology that can be used at low energy levels for short-range high-bandwidth communication using a large portion of the radio spectrum. UWB does not use conventional modulation techniques where a sinusoidal carrier is modulated by the message signal. Instead, it encodes data on short-duration (wideband) pulses to achieve high data rates. It supports forward error correction encoded data rates in excess of 675 Mbps [4]. UWB communication is designed for very short ranges (less than 1 m). Since UWB uses much lower power than conventional radios, it produces very low interference even though it occupies a large part of spectrum. Because of the wide bandwidth of UWB pulses, high timing accuracy and rejection of multipath effects can be achieved.

Timing accuracy enables UWB to be used as a technology for positioning applications where mobile terminals can determine their position based on difference in time of arrival of UWB pulses from fixed nodes in the surrounding environments [5]. Such a technique can find applications in intelligent transportation systems where a vehicle can determine its relative position compared to other vehicles, enabling better traffic coordination. UWB positioning can also be combined with a global positioning system (GPS) to provide a more accurate global position [5]. Very short range of communication is one of the drawbacks of UWB implementation. Increasing the range would mean operating at a higher power level which would cause interference with other frequency bands because of the large bandwidth of UWB systems.

Unfortunately, UWB has found difficult gaining a foothold in developing new products. Based on technological difficulties with performance, power, price and global regulatory issues market penetration has stalled. Intel has recently withdrawn their research efforts and venture capital for the technology is losing ground. The technology is still viable but will most likely not be a major medium for DOT applications in the short term.

2.7 IEEE 802.11p

IEEE 802.11p (also known as Wireless Access for Vehicular Environment or WAVE) is an amendment to the IEEE 802.11 standard and defines enhancements to support communication between high-speed vehicles and between vehicles and roadside infrastructure. It is defined to operate in the licensed 5.9 GHz band approved for intelligent transportation systems. Possible applications include emergency warning system, cooperative adaptive cruise control, cooperative collision avoidance, etc. [6]. Figure 5 shows one possible configuration for communication between an on-board unit (OBU) on a vehicle and a roadside unit (RSU) [6].

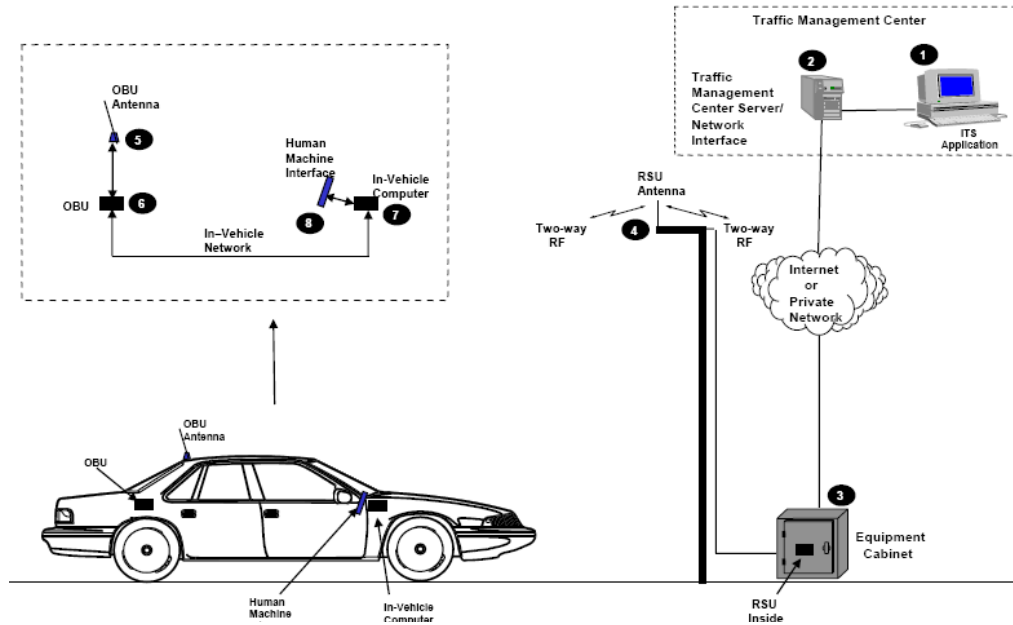

Figure 5 DSRC Architecture

Currently, the DSRC standards development has been moving slowly. There is some speculation by IT companies outside the transportation world that the actual standard will be 'dead on arrival'. This means that there will be limited development of products that follow this standard which will keep prices high. The true power of DSRC lies in the dedication of spectrum for a specific use by the FCC and not in the actual standard. Many wireless companies such as Cisco and Motorola can build a radio that will operate in this spectrum. It is speculated that companies will market wireless devices in this spectrum block and modify their existing 802.11a protocols to meet the requirements of VII and safety applications but will not use the published 802.11p standard. VII in general still seems to be moving forward though with less emphasis on DSRC as a required technology.

2.8 Femtocell Short Range Cellular

Femtocells are an emerging new wireless technology designed to extend cell phone coverage into the home. The typical architecture is to place a Femtocell inside the home and connect it to an Internet backbone [7]. This home-based cellular base station allows a cell phone user to obtain a full strength signal for optimized performance, yet uses an Internet backbone to connect into the operator's core network (see Figure 6).

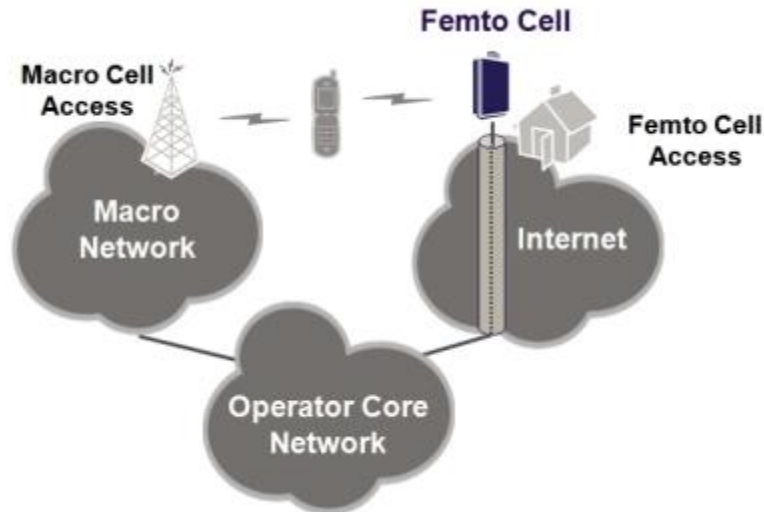

Figure 6 Femtocell Architecture

Consumer grade Femtocells are currently priced at \$200. Costs are estimated to fall to below \$100 by 2011 as production and competition increase [8].

The short-range, 'flat' architecture and mobility of cellular phones enables Femtocell technology to act as an alternative to DSRC. The Femtocell concept also provides a potential business plan that DSRC desperately lacks. One of the major hurdles for a DSRC based VII system is the lack of a business model for paying for the costs of infrastructure, deployment and maintenance. The OEM vehicle manufacturers are hesitant to increase the costs of their vehicles with a potentially expensive and power hungry DSRC radio. Additionally, the state DOT's are wary of who will be required to pay the bill for maintenance of devices connected into their signal infrastructure.

With Femtocell based architecture, the VII based information and safety applications could be an additional service to the cellular customer provided by the cellular service provider. The cellular service providers could pay for the infrastructure deployment and maintenance costs in exchange for charging the end users for additional services. This removes the burden of initial and long term costs from the federal and state DOTs. A significantly lower cost cellular phone board can be placed inside the vehicles in place of a DSRC radio. The cellular based on board unit (OBU) also provides the potential for a recurring revenue stream to the OEM vehicle manufactures by allowing them to charge users for regular upgrades to the system. Finally, there is also an opportunity for the USDOT to lease or auction off some of the 5.9GHz spectrum for use by the Femtocell service provider which has the potential to generate significant revenue as exemplified by the recent multi-billion dollar FCC auctions.

Some hard technical issues that need to be investigated include determining the latency between a Femtocell base station and a mobile user, defining the

scalability in terms of the number of users a Femtocell is capable of supporting, and defining the overall architecture of a VII based Femtocell system.

2.9 Long-Term Evolution (LTE)

LTE is the fourth generation (4G) standard for mobile communication from Global System for Mobile communication (GSM) family. It is currently being developed to provide data rates in excess of 100 Mbps on the downlink and 50 Mbps on the uplink [9]. LTE also uses packet-switched network (all-IP network) for both data and voice communication. It provides spectrum flexibility over current networks with spectrum slices ranging from 1.25MHz to 20MHz. Cell sizes range from 5 km (optimal performance) to 100 km (acceptable performance). It is backward compatible with current 2G and 3G networks. LTE uses OFDMA (a multiple access version of OFDM) for downlink and Single Carrier Frequency Division Multiple Access (SC-FDMA) for uplink. The reason for using SC-FDMA for uplink is its lower peak-to-average power ratio which improves battery life of handheld devices.

2.10 WiMAX

WiMAX (Worldwide Interoperability for Microwave Access) is a communications technology for providing last-mile wireless broadband access. It is based on the IEEE 802.16 standard and supports NLOS or indoor end-user terminals for fixed-only (IEEE 802.16-2004 or fixed WiMAX) or fixed/mobile (IEEE 802.16e or mobile WiMAX) access to the network. WiMAX supports a variety of network architectures from point-to-point links to mobile cellular networks. Data rates of up to 70 Mbps are supported at very short distances with throughput dropping to 10 Mbps at about 6 miles [10].

WiMAX employs OFDM for better performance in urban environments and better spectral efficiency. It also uses multiple input-multiple output (MIMO) schemes to combat multipath effects by increasing signal diversity. MIMO uses multiple antennas at the transmitter and the receiver, resulting in multiple copies of the message signal which helps to reduce error.

Although WiMAX is similar in deployment to WiFi (IEEE 802.11) it has some basic differences. Unlike WiFi, WiMAX typically operates in the licensed spectrum and has longer range. There are some unlicensed products on the market using the WiMAX MAC/PHY layer. Using licensed spectrum reduces interference to WiMAX stations while crowding in the unlicensed spectrum is increasingly becoming a cause for concern in WiFi networks. Better spectral efficiency of WiMAX means lower cost per user and that makes it an exciting alternative to providing connectivity through wired network. Other WiMAX features include handoff between base stations to facilitate user mobility and fractional frequency reuse (using only a fraction of available spectrum at cell edges to avoid interference from adjacent cells.)

Some of the possible applications of WiMAX as well as LTE in transportation include providing real-time localized weather and traffic updates, traffic monitoring, supporting video streaming and voice over IP calls in vehicles, etc. Availability of products from leading vendors like Intel and Motorola and earlier deployment than LTE makes WiMAX a leading candidate for 4G communications. However, its success is also tied to how much support it gets from service providers. The momentum for WiMAX deployment seems steady as the current Sprint/Clearwire partnership seems poised for nationwide deployment. Mobile WiMAX subscription services have significant potential for meeting the needs of DOT roadside data devices such as video, DMS and Roadway Weather Information System (RWIS). Fixed WiMAX also has applicability as backhaul for wireless networks though more testing is required to determine if fixed WiMAX is worth the cost compared to higher bandwidth direct sequence backhaul systems.

3.0 Recommended Technologies to Research

In this section, several research directions are suggested based on the near term availability of technologies and the needs of DOT operations.

3.1 Mobile WiMAX

Mobile WiMAX is the best emerging technology that has a high potential for application in DOT security operations. It has currently been under deployment for less than a year in the Richmond area; therefore, it is not a technology that is too far out on the timeline. Mobile WiMAX will lead next generation cell phone deployments by at least several years and there is a good chance that coverage will increase to cover most of the Commonwealth. The advantages of Mobile WiMAX include the NLOS operations and the high bandwidth capability. A monthly fee will be incurred due to the subscriber nature of the architecture; however, the ubiquity of its availability in a given region may overcome this drawback. In addition, the monthly costs will be significantly lower than T1 lines.

There has been little research performed in applying Mobile WiMAX to a DOT application such as video surveillance, DSRC backbone, or providing connectivity to DOT vehicles. Virginia Tech has relationships with WiMAX vendors such as Samsung. A test deployment on the Smart Road to simulate a highway deployment would provide valuable experience with this technology. A mobile WiMAX link could also be tied to the DSRC collision avoidance intersection on the Smart Road to simulate a backhaul for DSRC which supports the national VII vision.

3.2 Software Defined Radio/Cognitive radio

The ever changing nature of information technology makes any large scale wireless deployment in danger of obsolescence. Procurement timelines at the state and Federal levels often lag behind the rapid development of technology, making it difficult to deploy the state-of-the-art. The concept of SDRs and their reconfigurable nature is a good fit with the evolving nature of ITS deployments

and DOT operations. This makes SDR a candidate technology for further investigation.

The fundamental technology is available now; however, significant investigation is required to adapt the available platforms for specific DOT operations. It is suggested to assess the communications requirements of DOT ITS systems and perform a feasibility study of SDR applied to this environment. A prototype SDR based on a DSRC, 802.11 data link and possibly a commonly used DOT voice radio would provide a test bed platform for further development. In addition, a transportation-based SDR would provide a foundation platform for further development of Cognitive Radio applications for DOT operations to support spectrum agility and robust operations.

3.3 802.22 and Whitespace technologies

The incredible propagation characteristics of the 802.22 technology and the emerging whitespace technologies have significant potential to transportation operations. DOT operations span large geographical areas with limited communications infrastructure in place. The non-line-of-sight capability combined with the broadband throughput makes these very important to monitor in the near term.

4.0 Conclusions

The wireless landscape is on the cusp of significant change within the next 3-5 years. Broadband cellular based deployments are currently underway and the next wave of wireless standards is in approval stage. These developments are going to dramatically change the way wireless communications are used in our everyday life and the applications to transportation. It is recommended the DOTs investigate the applications of Mobile WiMAX, 802.22, Software Defined Radios and Femtocell cellular to the needs of Operations.

- [1] D. Jackson, 2008, *Comment period begins on D Block*, [Online]. Available: http://mrtmag.com/policy_and_law/news/comment-period-dblock-0523/
- [2] Wikipedia, *High speed packet access*, [Online]. Available: http://en.wikipedia.org/wiki/High-Speed_Packet_Access
- [3] Wikipedia, *IEEE 802.22*, [Online]. Available: http://en.wikipedia.org/wiki/IEEE_802.22
- [4] F. Mlinarsky, 2008, *Wireless HD video: Raising the UWB throughput bar (again)* [Online]. Available: <http://www.wirelessnetdesignline.com/206800520;jsessionid=YNKESA1HKXHGYQSNDLQSKHSCJUNN2JVN?printableArticle=true>
- [5] D. Harmer, 2004, *Ultra Wideband (UWB) Indoor Positioning*, [Online]. Available: http://esamultimedia.esa.int/docs/NavigationProjects/UWB_tech_Proj_Overview.pdf
- [6] B. Cash, 2004, *WAVE Background Information*, [Online]. Available: <http://www.npstc.org/meetings/Cash%20WAVE%20Information%20for%205.9%20GHz%20061404.pdf>
- [7] Airvanva, 2008, *Femtocell Technology*, [Online]. Available: http://www.airvananet.com/technology/technology_femto_cells.htm
- [8] Whydom, 2008, *Femtocell Residential Gateways: A \$2 Billion Market?*, [Online]. Available: <http://whydom.com/2007/08/28/femtocell-residential-gateways-a-2-billion-market/>
- [9] Wikipedia, *3GPP Long Term Evolution*, [Online]. Available: http://en.wikipedia.org/wiki/3GPP_Long_Term_Evolution
- [10] Wikipedia, *WiMax* [Online]. Available: <http://en.wikipedia.org/wiki/WiMAX>