

A POLYCOM WHITEPAPER

 H.264 High Profile:  
The Next Big Thing in Visual  
Communications

June 2010

## Introduction

With the introduction of the first and only H.264 High Profile implementation for real-time video, Polycom continues the tradition of bringing leading-edge video technology to the visual communication market. While H.264 is a well-established and widely implemented standard for video compression, the much simpler and less efficient Baseline Profile is used for visual communication applications today.

What is H.264? How is the High Profile different from other H.264 profiles? What is the impact of this new capability on the visual communication market? How will customers benefit from it? How will this technology help CIOs roll out video across organizations? How does High Profile interact with other video functions? What is its role in the Polycom Open Collaboration Network strategy? This white paper will look at High Profile from both the business and technology perspectives, and provide answers to these questions.

## The Impact of HD to the Visual Communication Market

High Definition (HD) video led to a rapid and total transformation of the visual communication market. The new generation of video systems provides crisp images and high frame rates that made real-time video look like a produced movie, a far cry from the low-quality video users experienced with previous generations of the technology. New applications emerged, most prominently immersive telepresence which combines HD video and audio technology with multiple screens and room design that is optimized for life-like interaction across distances. By 2008, most enterprise-grade video equipment shipped with HD support. The only drawback was the higher bandwidth required to compress the HD video images. This put additional scalability requirements on the video network infrastructure, which resulted in complete new scalable, redundant, and reliable solutions, as described in the white paper ["Scalable Architecture for Distributed Video."](#)

But while high-end telepresence systems and selected conference rooms were able to connect at HD quality through dedicated Virtual LANs and well-designed MPLS WANs, most regular users did not get immediate access to HD quality even if they had an HD-capable system. Few organizations had the network resource to allow HD video to flow freely. The frugality caused by the financial crisis in 2008 – 2009 did not allow most CIOs to upgrade networks that limited HD only to high-profile users, locations, or occasions.

In places where HD was widely deployed, however, users quickly discovered the benefit of high-quality picture and audio. HD video became a viable alternative to travel and face-to-face meetings. HD made visual communication much more attractive, and demand for mass deployment in organizations of any kind and size increased. The dilemma of CIOs today is how to meet user demand and requirements for HD communication while not breaking the bank for network upgrades.

Now that the systems support HD and the infrastructure is scalable and robust enough to support large HD deployments, bandwidth remains the last limiting factor to mass deployment of HD video across organizations. Timing is therefore perfect for a new technology breakthrough that dramatically decreases the bandwidth required to run HD and high-quality video.

## Advances in Video Compression Technology

Strong video standards have been in place since the emergence of visual communication with the ITU-T H.26x family of standards setting the bar for interoperability. The original H.261 standard was replaced by H.263 and followed by the latest H.264. All of these standards essentially describe how to compress video, so that it can be transmitted efficiently across real-world networks, and how to decompress it at the receiver side. A raw (uncompressed) HD video stream can be around 1 gigabit per second and clearly not appropriate for any but the few over-provisioned research networks. By applying the H.264 Baseline Profile, the 1 gigabit per second stream can be compressed to about 1 megabit per second, i.e., 1000-fold compression, which is a very impressive technical achievement in itself. However, if H.264 High Profile is used instead, the compressed video stream can be reduced to about 512 kilobits per second, i.e., 2000-fold. Figure 1 is a block diagram of the H.264 standard (encoder side). Note that capturing and playback of video are not in the scope of the standard.

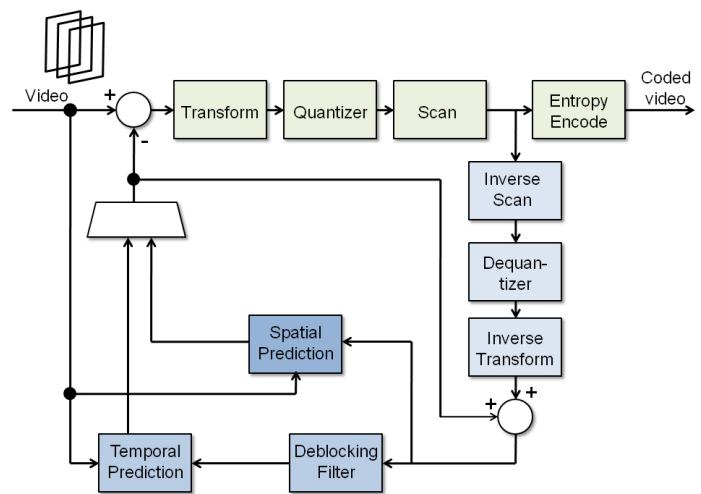

Figure 1: H.264 encoder block diagram

The H.264 standard lists multiple options for the implementation of each block, which allows vendors to develop customized applications and address the requirements in their markets. However, by following the block diagram and using options that are officially part of the H.264 standard, vendors preserve interoperability with other vendors. Deviations from the standard lead to incompatibility and interoperability problems.

All in all, H.264 is a toolbox that includes mandatory tools that all implementations must support and optional tools that implementers

can select from if they desire. Since hundreds of compression experts were involved in the standardization process, the list of optional tools is quite long. Some options in the H.264 were simpler and were immediately implemented. Others were complex and even not feasible at time of the standardization but were accepted anyway—to be implemented later—when enough processing power might be available to handle the complexity.

## H.264 Profiles

To better organize the long list of functions, H.264 groups them into several profiles with increasing complexity and performance. Figure 2 depicts the relationship between the four standardized profiles in H.264.

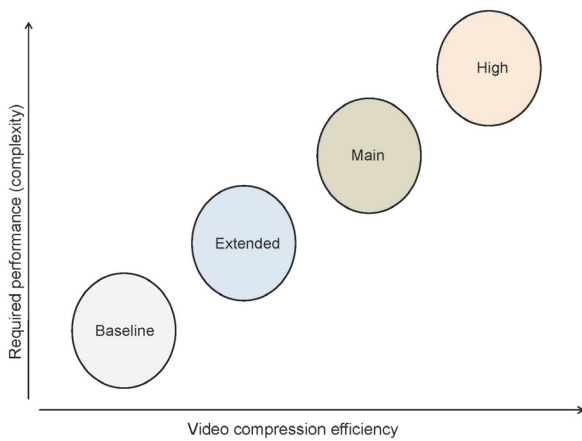

Figure 2: H.264 profiles

Most visual communication systems today use Baseline Profile. Baseline is the simplest H.264 profile and defines, for example, zigzag scanning of the picture and using 4:2:0 chrominance sampling. In Baseline Profile, the picture is split in blocks consisting of 4x4 pixels, and each block is processed separately. Another important element of the Baseline Profile is the use of Universal Variable Length Coding (UVLC) and Context Adaptive Variable Length Coding (CAVLC) entropy coding techniques. The encoding efficiency has a great impact on the network bandwidth for video, and advancements of the encoding technology contribute to the improved efficiency of the High Profile over Baseline, as discussed below.

The Extended and Main Profiles includes the functionality of the Baseline Profile and add improvements to the predictions algorithms. Since transmitting every single frame (think 30 frames per second for good quality video) is not feasible if you are trying to reduce the bit rate 1000-2000 times, temporal and motion prediction are heavily used in H.264, and allow transmitting only the difference between one frame and the previous frames. The result is spectacular efficiency gain, especially for scenes with little change and motion.

The High Profile is the most powerful profile in H.264, and it allows most efficient coding of video. For example, large coding gain is

achieved through the use of Context Adaptive Binary Arithmetic Coding (CABAC) encoding which is more efficient than the UVLC/CAVLC used in Baseline Profile.

The High Profile also uses adaptive transform that decides on the fly if 4x4 or 8x8-pixel blocks should be used. For example, 4x4 blocks are used for the parts of the picture that are dense with detail, while parts that have little detail are transformed using 8x8 blocks.

H.264 also provides a decoder block diagram, which we will not discuss in this paper due to the large overlap with the encoding functionality, and to keep the paper concise.

## Key Benefits of High Profile

The ability to preserve video quality and dramatically reduce the required network bandwidth impacts all areas of video networking. High Profile therefore reduces the cost of new and existing video deployments, and accelerates return on investment (ROI).

### Reducing Cost of New Video Deployments

Most recently, new video deployments typically start with evaluation of the IP network and usually require upgrades to increase bandwidth and remove bottlenecks. High Profile reduces the required network bandwidth for video by up to 50%. High Definition video calls that required over 1 megabit per second using Baseline Profile are now supported at just 512 kilobits per second with High Profile. Standard Definition calls that required a minimum of 256 kilobits per second are now supported at as low as 128 kilobits per second. Figure 3 compares the bandwidth requirements for video with High and Baseline Profiles.

Resolution / Frame Rate	H.264 Baseline Profile (Industry Norm Today) Call Speed in kbps	H.264 High Profile Only from Polycom Call Speed in kbps	Polycom Bandwidth Reduction
CIF 30	128	64	<b>Up to 50 %!</b>
4CIF30	256	128	
4CIF60	1024	512	
720p30	1024	512	
720p60	1512	832	
1080p30	2048	1024	

Figure 3: Bandwidth consumption for different video quality levels with Baseline and High profiles

High Profile dramatically lowers a key barrier to entry for visual communication, allowing broader deployments across more organizations. CIOs concerned that adding video or integrating video into their UC applications may overwhelm their IP networks now have the option to roll out video without redesigning their entire networks.

### Reducing Cost of Existing Video Deployments

Polycom is now the only provider of the High Profile technology. Polycom® HDX® telepresence users can move to High Profile simply by upgrading their HDX (IP versions, not ISDN) software to release 2.6. The following HDX hardware can be used: all HDX 6000 (receives up to 720p60 and 1080p30, transmits up to 720p30 and 1080p15), HDX 7002 Rev C (shipping since early February 2010), HDX 8002/8004/8006 Rev B (shipping since January 2009), and HDX 9000 Rev. B (shipping since April 2010).

Since most video calls today are placed at 512 – 768 kilobits per second, the upgrade to High Profile will mean, to most users, moving from Standard Definition to High Definition video. As discussed above, HD is proven to not only increase productivity but to also enable immersive experiences, effectively replace face-to-face meetings, and lead to travel reduction and immediate cost savings for the organization.

For network administrators, High Profile is a green light for rolling out video to larger user groups. For example, the network resource necessary to run 1000 video calls in the past is now sufficient to support up to 2000 video calls. Since High Profile is even supported in the most affordable room telepresence systems such as HDX 6000, even small conference rooms benefit.

Figure 4 shows what happens in the IP network when High Profile is gradually introduced, for example, through upgrades of existing systems or the installation of new ones.

### Deeper Impact of High Profile Technology

Polycom's H.264 High Profile technology is universally applicable to video-enabled elements in the network. It is therefore being rolled out to an increasing number of products in the Polycom portfolio in 2010 to provide additional value to Polycom customers.

High Profile roll-out will follow the standard pattern of implementing new technology throughout the entire Polycom portfolio. Video endpoints (HDX) are usually the first to be enabled with a new technology; this is no different with High Profile. Conferencing servers (Polycom RMX® 2000/4000) follow within short period of time, since a single conference server must meet the increased performance requirements for dozens and even hundreds of video calls at the same time. The Polycom RMX 2000/4000 platform, Version 7.0, will extend the benefits of H.264 High Profile to multipoint conferencing in the third quarter of 2010. Due to the advanced transcoding capabilities in the Polycom RMX platform, users connected to the conference server through High Profile-enabled HDX endpoints will enjoy high quality at lower bandwidth while users connected through endpoints that do not support High Profile will continue to use higher bandwidth for the equivalent quality. This approach protects the customer's investment in endpoints and allows for gradual replacement and migration to High Profile-enabled endpoints.

Since Polycom's immersive telepresence systems use HDX video endpoint technology, the new functionality will also become available on immersive telepresence systems (the Polycom RPX™, TPX®, ATX®, and OTX™ solutions) in the third quarter of 2010 with Version 2.7. Since Polycom immersive telepresence rooms contain multiple HDX video codecs, the bandwidth savings are multiplied, and dramatically accelerate ROI.

Once the critical mass in the video network is achieved, new technology is extended to soft clients and recording/streaming servers. This technology deployment model allows broad field testing of the new technology on the endpoints and then rapidly disseminating it throughout the entire Polycom solution portfolio.

Here are some examples how High Profile changes the rules in the video network design:

First, High Profile improves the quality and delivers large cost savings with large immersive telepresence application, such as RPX, TPX, ATX, and OTX solutions. To assure perfect quality, these applications usually use 4 megabits per second per screen with the H.264 Baseline Profile, which is already a very efficient use of the network resource compared to competitive systems. High Profile pushes the efficiency bar even higher and allows Polycom immersive telepresence systems to deliver comparable video quality and experience at much lower bandwidths, that is, in the range of 2 megabits per second per screen.

Second, High Profile relaxes the bandwidth requirements for connecting conferencing servers to the IP network. Conferencing servers, such as the RMX 2000/4000 solutions, are in the core of the visual

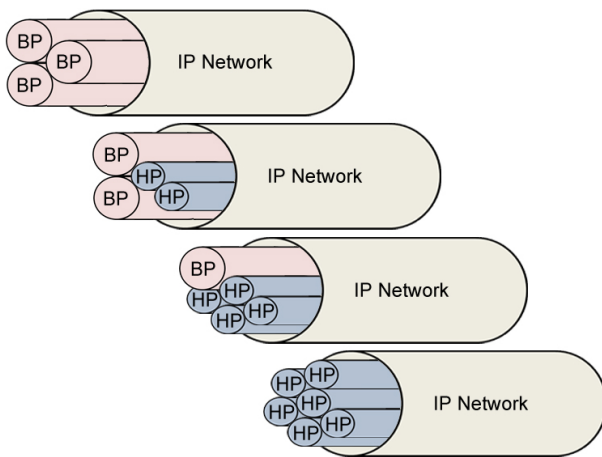

Figure 4: Migration from H.264 Baseline to High Profile increases network capacity

Note that the video quality remains unchanged while the network traffic gets lighter. In this example, the IP network which originally carried 3 Baseline Profile video calls is able to carry up to 6 High Profile video calls at the end of the migration. High Profile therefore enables higher scalability and allows CIOs to meet the growing demand for HD communication in their organizations.

communication network, and must therefore be connected at very high bandwidth. For example, if the conferencing server supports 80 HD calls at 1 megabit per second each, it has to be connected in a part of the IP network that can carry 80 megabits per second. High Profile relaxes this requirement and allows a similar conferencing server to deliver equivalent quality and scale over a link with just 40 megabits per second.

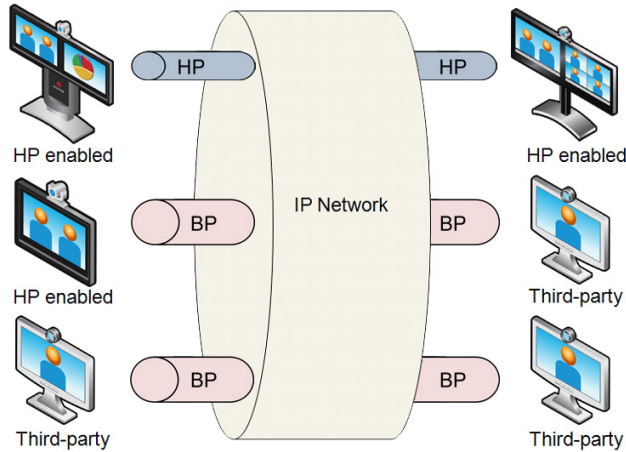

Figure 5: Interoperability scenarios with network

Third, High Profile will allow more teleworkers and road warriors to access the corporate network at higher quality. Video Border Proxies (VBPs) are the gates to the corporate video network and their throughput has traditionally limited visual communication from off site. With the deployment of High Profile, the existing VBPs in the organization can approximately double their capacity. For example, a VBP 6400 E with 85 megabits per second throughput that supports 85 Baseline Profile HD video calls can easily support 170 High Profile HD calls.

### Accelerated Return on Investment

The introduction of High Profile preserves interoperability across the Polycom solution and with other standards-based systems. Polycom HDX systems upgraded to High Profile will always prefer the use of High Profile with other High Profile-capable video network elements. Polycom HDX continues to support H.264 Baseline Profile for communication with, for example, third-party systems. Figure 5 depicts the interoperability scenarios.

Two High Profile-enabled systems—for example, two HDXs or an HDX and an RMX—will always negotiate the use of High Profile, and save bandwidth (top scenario). However, if one of the communication parties does not support High Profile, the capability negotiation process will lead to the use of Baseline Profile, as shown in the middle and bottom scenarios.

Therefore, Polycom's implementation of High Profile preserves interoperability across the visual communication network and protects customer investments.

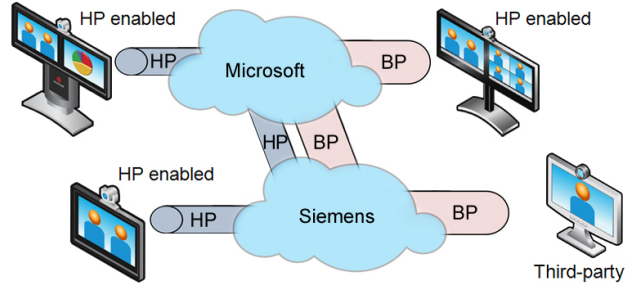

Figure 6: Providing Polycom H.264 experience across UC environments

High Profile allows CIOs to limit or avoid IP network upgrades when supporting or expanding visual communication deployments. IP network upgrades are a major contributor to the overall deployment cost, and relaxing the bandwidth requirements immediately reduces the number and scope of necessary upgrades to ready the IP network for video traffic. Lower upfront cost leads to shorter ROI.

High Profile is a new addition to Polycom's vast standard-based video capabilities, and it does not take away any of the functionality customers already have. Polycom Lost Packet Recovery™ technology, a Polycom-exclusive technology, works seamlessly with High Profile to provide superior quality in imperfect networks with packet loss. The introduction of High Profile will have no impact on Polycom People+Content collaboration technology for content sharing

High Profile support is one more way Polycom adds value to the Polycom Open Collaboration Network. The use of High Profile is negotiated among Polycom network elements that may be connected to UC environments from BroadSoft, HP, IBM, Juniper, Microsoft, and Siemens. Figure 6 depicts a mixed UC configuration with Polycom elements using High Profile to communicate.

In this example, two High Profile-capable Polycom systems are connected to Microsoft OCS while a Polycom High Profile-enabled system and a third-party system are connected to Siemens OpenScape. Assuming that the dialing plans are configured between the two UC environments, Polycom systems can talk to each other and negotiate the parameters of the video call. As discussed above, High Profile-enabled Polycom systems will always negotiate to use it and save bandwidth. Third-party video systems like the one connected to the Siemens UC environment can also connect but will use the less efficient Baseline Profile.

This configuration is a perfect example of the power of the Polycom Open Collaboration Network, which delivers the unique benefits of Polycom solutions across UC environments while preserving interoperability with third-party and legacy systems.

## Conclusion

Polycom's introduction of High Profile is a technology breakthrough that enables a dramatic reduction of the network resources necessary to video-enable organizations. It allows CIOs to meet budget challenges and power more visual communication with fewer resources, thus limiting or avoiding costly network upgrades.

The shift from Baseline Profile to High Profile is bigger and more important than the previous video technology breakthrough—the much-heralded shift from H.263 to H.264 in 2003. The gains in performance from the use of High Profile are consistent across the full bandwidth spectrum, while the incremental gain from H.264 over H.263 was limited to the lower bandwidths, below 512 kilobits per second. As a result, new High Definition systems benefit the most from High Profile, and this new technology will accelerate the adoption of HD communication across organizations.

## About the Author

Stefan Karapetkov is Emerging Technologies Director at Polycom, Inc. where he focuses on visual communications market and technology analysis. Prior to Polycom, he spent more than 10 years with Siemens in product management, new technology development and enterprise product definition. He has been involved in Voice over IP since 1997.

Stefan Karapetkov has MBA from Santa Clara University and an MS degree in Engineering from the University of Chemnitz (Germany). He is fluent in English, German, Russian, and Bulgarian.

## Acknowledgements

I would like to thank my colleague John Antanaitis for his contributions to this work.